

# Specifications

## Table of Contents

<b>Conditions of Sale</b> .....	<b>2</b>	<b>Application Classification</b> .....	<b>6</b>
Standard.....	2	<b>Ordering Tables</b> .....	<b>9</b>
Special To This Product.....	2	<b>Dimensional Drawings</b> .....	<b>19</b>
<b>How to Order</b> .....	<b>5</b>		



### Standard

The seller's standard conditions of sale set forth in Price Sheet 150 apply, except as modified under the "Special Warranty Provisions" on page 4 and "Warranty Qualifications" sections on page 4.

### Special To This Product

#### Inclusions

The Mark V Circuit-Switcher uses an in-series circuit-breaking interrupter and a circuit-making and isolating disconnect, making it especially suited for switching and protection of transformers, lines, cables, capacitor banks, and line-connected or tertiary-connected shunt reactors. The Mark V Circuit-Switcher is suitable for frequent operation over a long period of time with minimal maintenance. It is capable of closing, carrying, and interrupting fault currents as well as load currents, and it uses interrupters economically tailored for specific applications by using the precise number of interrupting gaps required. These interrupters are unaffected if subjected to sustained system voltage for extended periods resulting from being left open with the disconnect blades closed for any reason. The Mark V Circuit-Switcher is available in three styles—vertical-break, center-break, and integer.

#### Power Operation

High-speed, high-torque power operation of S&C Mark V Circuit-Switchers is required to provide two-time duty-cycle fault-closing ratings of 30,000 amperes, RMS, three-phase symmetrical, 76,500 amperes peak for the vertical-break style and integer-style circuit-switchers; and two-time duty-cycle fault-closing ratings of 40,000 amperes, RMS, three-phase symmetrical, 102,000 amperes peak for the center-break style circuit-switchers. See the "Basis of Fault-Closing Ratings" section. Power operation of Mark V Circuit-Switchers also provides opening and closing without hesitation under  $\frac{3}{4}$ -inch (19-mm) ice formation for the vertical-break and integer styles,  $1\frac{1}{2}$ -inch (38-mm) ice formation for the center-break style, close interphase simultaneity, long life of fault-closing contacts under normal operating duties, and avoidance of excessive switching transients caused by prolonged or unstable prestrike arcing. Mark V Circuit-Switchers are provided with high-speed, high-torque power operation by adding Type CS-1A Switch Operators. Refer to S&C Specification Bulletin 719-31 for details on Type CS-1A Switch Operators.

For high-speed tripping of power-operated Mark V Circuit-Switchers, add an optional S&C Shunt-Trip Device. See Table 7 on page 12. This shunt-trip device provides high-speed (8-cycle) circuit interruption. The Type CS-1A Switch Operator is required if the shunt-trip device is specified.

#### Basis of Fault-Closing Ratings

Two-time duty-cycle fault-closing ratings, as set forth above and on succeeding pages, apply to Mark V Circuit-Switchers when powered by the Type CS-1A Switch Operator and are based on performance as follows:

1. The circuit-switcher is capable of two fault-closing operations consisting of closing against and carrying for three seconds● its rated fault-closing current, after which it can carry and interrupt its rated continuous current and is capable of power operation—either opening or closing.
2. After each occasion consisting of either one or two fault-closing operations at its rated fault-closing current, the circuit-switcher must be inspected and any necessary repair or replacement of the fault-closing contacts made to restore the device to its original condition.

#### Manual Operation

Integer-style, vertical-break style, and center-break style Mark V Circuit-Switchers (with extruded-aluminum weldment bases)—are all available for manual operation. Manually operated circuit-switchers, however, do not provide the performance features obtainable with power-operated circuit-switchers described in the "Power Operation" section on page 2 such as fault-closing ratings and opening and closing under ice formation, nor can they be furnished with the shunt-trip device. Also, for manually operated Mark V Circuit-Switchers, the degree of simultaneity of opening and closing of the three pole-units depends on the proper installation and adjustment of the operating mechanism—as well as on the speed of cranking at the operating handle—and must be considered in establishing ground-relay settings. If manual operation is desired, specify the S&C Manual Geared Operating Handle listed in Table 9 on page 16.

● 10 cycles for center-break style circuit-switchers.

**Mounting of Circuit-Switchers**

The high operating speed makes possible many of the Mark-V Circuit-Switcher's superior performance features when power-operated (described on page 2) and brings about the high dynamic forces for which S&C Mounting Pedestals were specifically designed—and are thus highly recommended. See Table 13 on page 18. Alternately, circuit-switchers can be installed on the user's steel pedestals or supporting structures, which must meet specific static and dynamic deflection limits shown on the data sheets listed in Table 1.

**Table 1. Static and Dynamic Deflection Limit Resources**

Circuit-Switcher Style and Rating	Static and Dynamic Loading Specifications
Vertical-break, 34.5 through 161 kV	Data Sheet 711-300
Center-break, 230 kV: extruded-aluminum weldment base	Data Sheet 711-301
Center-break, 345 kV: aluminum-sheathed steel weldment base	Data Sheet 711-302
Integer, 34.5 through 69 kV	Data Sheet 711-303

**Exclusions**

Mark V Circuit-Switchers do not include connectors. Various connectors are available, as listed in Table 8 on page 15. Specify the quantity and catalog number of the connectors desired.

Circuit-switchers do not include manual operating handles.

Mounting pedestals and anchor bolts, if furnished, are not included and must be ordered separately. For mounting pedestals and anchor bolts, see Table 13 on page 18.

Circuit-switchers do not include the services of an S&C field service specialist for evaluating the condition of the circuit-switcher.

**Specification Deviations**

When Mark V Circuit-Switchers are to be provided with special connectors (including all expansion, compression, and multi-conductor types), refer to the nearest S&C Sales Office.

Single-, two-, and four-pole vertical-break style and center-break style circuit-switchers are available. Refer to the nearest S&C Sales Office.

**Usual Operating Conditions**

Mark V Circuit-Switchers will perform as intended at temperatures within the range of -40°C to + 40°C (-40°F to + 104°F), at altitudes of up to 3300 feet (1000 meters),●, and at wind loadings of up to 100 miles per hour (160 kilometers per hour).

Mark V Circuit-Switchers, when installed with the recommended S&C Mounting Pedestals and anchor bolts (see Table 13 on page 18), are capable of withstanding seismic loading of 0.2-g ground acceleration in any direction, as well as performing as intended during such loading and afterward.

For applications at temperatures not within the specified range, at higher altitudes, at higher wind loadings, or where higher seismic withstand capabilities are required, refer to the nearest S&C Sales Office.

● Mark V Circuit-Switchers can be installed at altitudes greater than 3300 feet (1000 meters), but deratings to the BIL voltage will apply. Refer to the nearest S&C Sales Office for details.

## Conditions of Sale

---

### **Special Warranty Provisions**

The standard warranty contained in the seller's standard conditions of sale, as set forth in Price Sheet 150, applies to Mark V Circuit-Switchers and accessories and associated switch operators, except the first paragraph of the said warranty is replaced by the following:

**(1) General:** The seller warrants to the purchaser for a period of five years from the date of shipment that the equipment delivered will be of the kind and quality specified in the contract description and will be free of defects of workmanship and material. Should any failure to conform to this warranty appear under proper and normal use within five years after the date of shipment, the seller agrees, upon prompt notification thereof and confirmation that the equipment has been stored, installed, operated, inspected, and maintained in accordance with recommendations of the seller and standard industry practice, to correct the nonconformity either by repairing any damaged or defective parts of the equipment or (at the seller's option) by shipment of necessary replacement parts.

Replacement parts provided by the seller under the warranty for the original equipment will be covered by the original-equipment warranty for its duration. Replacement parts purchased separately will be covered by the warranty contained in the seller's standard conditions of sale, as set forth in Price Sheet 150.

### **Warranty Qualifications**

Warranty of circuit-switchers is contingent upon each of the following:

- Observance of the static and dynamic deflection limits shown on S&C Information Bulletin 711-300, 711-301, or 711-303, as applicable and S&C Data Sheet 711-302
- Power operation of circuit-switchers only by S&C Switch Operators
- Installation and adjustment of circuit-switchers in accordance with S&C's applicable erection drawings and instruction sheets
- Conformance with the inspection recommendations defined in S&C Instruction Sheet 711-590

Complete these steps to identify the base catalog number, the appropriate options, and the product accessories to complete this order:

**STEP 1.** Obtain the catalog number of the desired circuit-switcher from Table 3 on page 9, Table 4 on page 10, and Table 5 and Table 6 on page 11.

Catalog Number: 1 5 7 3 1 4

**STEP 2.** Obtain the suffix letters of optional features, if desired, from Table 7 on page 12 through page 15. Add the indicated suffix letter(s) to the catalog number of the circuit-switcher selected in Step 1.

Catalog Number: 1 5 7 3 1 4

Suffix: — T 1

**STEP 3.** Obtain the catalog number of the mounting pedestal(s), if desired, from Table 13 on page 18. From this same table, obtain the catalog number of the required anchor bolts, taking care to note the quantity of anchor bolts required for the circuit-switcher selected.

Catalog Number: 9 2 4 5 0 R 1 — G

Catalog Number: S — 8 1 3 6 5 — 2

**STEP 4.** Select a manual handle or switch operator.

**If manual operation is desired:** Order an S&C Manual Geared Operating Handle. Obtain the catalog number for the manual handle from Table 9 on page 16.

**If accessories for the manual geared operating handle are desired:** Obtain the suffix letters of the desired accessories from Table 10 on page 16. Add the indicated suffix letter(s) to the catalog number of the operating handle.

Catalog Number: 5 2 9 1 — F 1

Suffix: — F 1

If power operation is desired, order a Type CS-1A Switch Operator. Refer to Specification Bulletin 719-31 for catalog and ordering information.

**STEP 5.** If connectors are desired, obtain the catalog number of the desired connector from Table 8 on page 15. Order six connectors for each circuit-switcher.

Catalog Number: 4 5 6 8

**Example:** The final catalog number for a complete order that includes a 138-kV, 1200-A continuous circuit-switcher, two interrupting gaps, with pre-assembly and a 125-Vdc shunt-trip device would be:

1 5 7 3 2 9 — A T 2

**Note:** All Mark V Circuit-Switcher orders must be designed by S&C's Custom Engineering team. Spare or replacement interrupters for Mark V Circuit-Switchers are ordered using the same method outlined above.

# Application Classification

**Table 2. Application Classifications**

Application		Maximum Amperes, Interrupting, RMS, Symmetrical	Symbol		
			Solidly or Effectively <sup>①</sup> Grounded System	Ungrounded System	
Class	Qualifications				
Transformer Switching and Protection	Parallel switching	Max 60-Hertz recovery voltage: 90 kV, RMS <sup>⑤</sup>	1200/1600/2000●	M	M
		Max 60-Hertz recovery voltage: 150 kV, RMS <sup>⑤</sup>	1200/1600/2000●	M	N
	Load dropping and magnetizing current switching	Transformers <sup>⑥</sup> connected solidly grounded-wye on the primary (circuit-switcher) side and delta on the secondary side	■	E	—
		All other connections of transformers <sup>⑥</sup>	■	B	B
	Fault interrupting <sup>④</sup>	Primary faults—with the total connected length of all lines on the source side of the circuit-switcher not less than that indicated in footnote <sup>⑦</sup>	7000 or 8000▲◆	J	J
		Primary faults—with the total connected length of all lines on the source side of the circuit-switcher less than that indicated in footnote <sup>⑦</sup>	4000▲▼	G	G
		Secondary faults—transformers <sup>⑥</sup> connected solidly grounded-wye on the primary (circuit-switcher) side and delta on the secondary side	4000□▲	△	G
		Secondary faults—all other connections of transformers	4000□▲	G	G
Internal faults—see both primary and secondary faults, above					
Line Switching and Protection	Load splitting (parallel or loop switching)	Max 60-Hertz recovery voltage: 90 kV, RMS <sup>⑤</sup>	1200/1600/2000●	M	M
		Max 60-Hertz recovery voltage: 150 kV, RMS <sup>⑤</sup>	1200/1600/2000●	N	N
	Load dropping	Circuits with <i>all</i> load-side transformers <sup>⑥</sup> connected solidly grounded-wye on the primary (circuit-switcher) side and delta on the secondary side <sup>⑧</sup>	1200/1600/2000●	E	—
		Circuits with load-side transformers connected other than as described above	1200/1600/2000●	B	B
	Line dropping		◇	K	L
	Fault interrupting <sup>④</sup>	Line or bus faults—with the total connected length of all lines on the source side of the circuit-switcher <i>not less than</i> that indicated in footnote <sup>⑦</sup>	7000 or 8000▲▼	J	J
		Line or bus faults—with the total connected length of all lines on the source side of the circuit-switcher <i>less than</i> that indicated in footnote <sup>⑦</sup>	4000▲▼	G	G

TABLE CONTINUED ►

Table 2. Application Classifications—Continued

Class		Application Qualifications		Maximum Amperes, Interrupting, RMS, Symmetrical	Symbol	
					Solidly or Effectively <sup>①</sup> Grounded System	Ungrounded System
Cable Switching and Protection	Load splitting (parallel or loop switching)	Max 60-Hertz recovery voltage: 90 kV, RMS <sup>⑤</sup>		1200/1600/2000●	M	M
		Max 60-Hertz recovery voltage: 150 kV, RMS <sup>⑤</sup>		1200/1600/2000 ●	N	N
	Load dropping	Circuits with all load-side transformers <sup>⑥</sup> connected solidly grounded-wye on the primary (circuit-switcher) side and delta on the secondary side <sup>⑧</sup>		1200/1600/2000●	E	—
		Circuits with load-side transformers connected other than as described above		1200/1600/2000●	B	B
	Cable dropping (charging current)	Shielded cable		550	H	L
		Unshielded cable		550	K	L
	Fault interrupting <sup>④</sup>	Cable or bus faults—with any total connected length of cable, and with a total connected length of all overhead lines on the source side of the circuit-switcher not less than that indicated in footnote <sup>⑦</sup>		7000 or 8000▲◐	J	J
		Cable or bus faults—with any total connected length of cable, but with a total connected length of all overhead lines on the source side of the circuit-switcher less than that indicated in footnote <sup>⑦</sup>		4000▲▼	G	G
Shunt Capacitor Bank <sup>②</sup> Switching and Protection <sup>③</sup>	Bank current switching	Grounded capacitor bank	Applications on solidly grounded systems through 69 kV	1000◐	H	—
			All other applications	550	H	L
		Ungrounded capacitor bank		550	L	L
	Fault interrupting <sup>④</sup>	Primary faults—with the total connected length of all lines on the source side of the circuit-switcher <i>not less than</i> that indicated in footnote <sup>⑦</sup>		7000 or 8000▲◆	◐	L
Primary faults—with the total connected length of all lines on the source side of the circuit-switcher less than that indicated in footnote <sup>⑦</sup>		4000▲▼	◐	L		
Series Reactor Switching		Refer to the nearest S&C Sales Office				
Shunt Reactor Switching and Protection (line-connected or tertiary-connected reactors)	Reactor current switching	Reactor wye-connected with solidly grounded neutral		1000▽■	P	R
		Reactor delta-connected, or wye-connected with ungrounded neutral <sup>⑨</sup>		1000▽■	R	R
	Fault interrupting <sup>④</sup>	Oil-insulated reactors		2800▲	◀	R
		Air-insulated reactors		2000▲	◀	R

①  $X_0/X1$  from 0 to + 3.0 and  $R0 /X1$  from 0 to + 1.0.  
 ② Includes both single and multiple (back-to-back) banks.  
 ③ S&C BankGuard Plus<sup>®</sup> Controls, described and listed in S&C Specification Bulletin 1011-31 have the sensitivity to detect the first faulted unit in a capacitor bank or to promptly respond to a shorted-turns fault in a shunt reactor—but with the discrimination to disregard system and bank unbalances as well as spurious transients. For installations of S&C Automatic Control Devices on, or in the same substation with, 345-kV or 500-kV circuits, contact the nearest S&C Sales Office.

④ The interrupting ratings shown are applicable for the following reclosing duty cycle: O + 0 seconds (no intentional delay) + CO + 0 seconds + CO.  
 ⑤ For integer-style circuit-switchers (except catalog numbers 157886 and 157986) the maximum 60-Hertz recovery voltage is 75 kV, RMS.  
 ⑥ Three-phase transformers or three-phase banks of single-phase transformers.

FOOTNOTES CONTINUED ►

# Application Classification

TABLE 2 FOOTNOTES CONTINUED

⑦ Total connected length of all overhead lines (in all directions), including any number of feeders connected to source-side substations, as indicated in table below. Connected cable may reduce or eliminate the line-length requirement. Contact the nearest S&C Sales Office.

System Voltage, kV →	34.5 thru 69	115 and 138	161	230	345
Total Length, Miles (km) →	7 (11)	15 (24)	20 (32)	25 (40)	40 (64)

⑧ And all single-phase transformers connected phase-to-ground on the primary (circuit-switcher) side.

⑨ For applications involving wye-connected reactor banks with neutral grounded through a fourth reactor, contact the nearest S&C Sales Office.

● Depending upon continuous rating of the circuit-switcher.

■ Circuit-switcher will drop loads through 1200, 1600, or 2000 amperes, depending upon its continuous rating, and will switch magnetizing currents associated with such loads.

▲ Tripping of a circuit-switcher must be coordinated with a series power fuse or with source-side protective equipment for short-circuit currents in excess of this value.

◆ 8000 amperes for all Mark V Circuit-Switcher models rated 34.5 kV through 69 kV, also 2-gap models rated 115 kV and 3-gap models rated 138 kV and 161 kV; 7000 amperes for all other Mark V Circuit-Switchers for which symbol "J" applies.

▼ 3000 amperes for 115-kV single-gap Mark V Circuit-Switchers.

□ The Mark V Circuit-Switcher is suitable for transformer-primary applications where the *inherent* secondary-fault current—the secondary-side fault current as reflected on the primary side of the transformer, assuming an infinite (zero-impedance) source—does not exceed 4000 amperes (3000 amperes in the case of 115-kV single-gap Mark V Circuit-Switchers) for a fault external to the transformer. The *inherent* secondary-fault current may be calculated as follows:

$$I = \frac{57.8P}{(\%Z)E}$$

where I = Inherent secondary-fault current, amperes

P = Transformer self-cooled three-phase rating, kVA

E = Primary-side system phase-to-phase voltage, kV

%Z = Percent transformer primary-to-secondary impedance, referred to transformer self-cooled three-phase kVA rating

For applications where the *inherent* secondary-fault current exceeds the above limits but where the maximum expected fault current, based on transformer impedance *plus* source impedance (anticipating future system growth), is within these limits, contact the nearest S&C Sales Office.

△ Symbol "E" for solidly grounded systems; symbol "F" for effectively grounded systems.

◇ Maximum length of line: 300 miles.

▽ For vertical-break and integer style circuit-switcher applications where load in excess of 550 amperes is to be switched frequently, extra-performance closing contacts are recommended for increased contact life; refer to the Table 7 on page 12 through page 15.

● Symbol "K" for solidly grounded capacitor banks applied on solidly grounded systems; symbol "L" for all other applications.

■ For center-break style circuit-switcher reactor switching applications above 500 amperes, contact the nearest S&C Sales Office.

▲ For applications up to 4000 amperes, contact the nearest S&C Sales Office.

◀ Symbol "P" for solidly grounded reactors applied on solidly grounded systems, provided phase-to-phase and ungrounded three-phase faults are cleared by other devices; symbol "R" for all other applications.

**Table 3. Circuit-Switchers—Three-Pole Vertical-Break Style<sup>①②③</sup>**

Ratings							No. of Interrupting Gaps	Application Classifications (see Table 2 on page 6)	Insulator T.R. No.	Leakage Distance, Inches (mm)	Catalog Number <sup>⑤</sup>	Page Reference for Dimensional Information
kV			Amperes, RMS									
Nom.	Max.	BIL	Cont.	Short-Time		Fault-Closing, Duty-Cycle, Two-Time <sup>④</sup>						
				Mom.	3-Sec.							
34.5	38	200	1200	61 000	40 000	30 000	1	BEFGHJKLMPR	210	37 (940)	157314	19
46	48.3	250	1200	61 000	40 000	30 000	1	BEFGHJKLMPR	214	43 (1092)	157315	
69	72.5	350	1200	61 000	40 000	30 000	1	BEFGHJKMP	216	72 (1829)	157316	
							2	BEFGHJKLMPR	216		157326	
115	121	550	1200	61 000	40 000	30 000	1	BEFGJM	286	99 (2515)	157318	
							2	BEFGHJKLMNPR	286		157328	
138	145	650	1200	61 000	40 000	30 000	2	BEFGHJKMNP	288	116 (2946)	157329	
							3	BEFGHJKLMNPR	288		157369	
161	169	750	1200	61 000	40 000	30 000	2	BEFGHJKMNP	291	132 (3353)	157320	
							3	BEFGHJKLMNPR	291		157360	

① Circuit-switchers do not include connectors. Refer to Table 8 on page 15. Circuit-switchers are furnished with gray (Munsell Number 5 BG 7.0/014) station post insulators.

② Circuit-switchers do not include manual operating handles. (See Table 9 on page 16.)

③ Shunt-trip device is available with all power-operated Vertical-Break Style Mark V Circuit-Switchers.

④ For complete information refer to the “Basis of Fault-Closing Ratings” section on page 2.

⑤ If the circuit-switcher is to be installed on a structure other than S&C Mounting Pedestals (see Table 13 on page 18), detailed drawings of the user-furnished mounting structure must be supplied at the time of order. Please contact your nearest S&C Sales Office for details.

## Ordering Tables

**Table 4. Circuit-Switchers—Three-Pole Center-Break Style, with Extruded-Aluminum Weldment Bases**①②③④⑤

Ratings							No. of Interrupting Gaps	Application Classifications (see Table 2 on page 6)	Insulator T.R. No.	Leakage Distance, Inches (mm)	Catalog Number⑦	Page Reference for Dimensional Information
kV			Amperes, RMS									
Nom.	Max.	BIL	Cont.	Short-Time		Fault-Closing, Duty-Cycle, Two-Time⑥						
				Mom.	3-Sec.							
230	242	900	1600	70 000	42 750	40 000	3	BEFGHJKMNP	308	165 (4191)	657361R2	21
			2000	80 000	50 000	40 000	3	BEFGHJKMNP	308	165 (4191)	757361R2	

① Circuit-switchers do not include connectors. Refer to Table 8 on page 15. Circuit-switchers are furnished with gray (Munsell Number 5 BG 7.0/014) station post insulators.

② Circuit-switchers do not include manual operating handles. (See Table 9 on page 16.)

③ Shunt-trip device is available with all power-operated center-break style Mark V Circuit-Switchers.

④ For center-break style circuit-switchers, blade opening direction, as viewed from interrupter end, is to the left.

⑤ Flexible-conductor connections are recommended at both ends of all center-break style circuit-switchers with extruded-aluminum weldment bases, except when the bypass accessory (catalog number suffix “-B2”) is furnished. In this instance, a rigid bus connection is necessary at the rotating-insulator end. To reduce circuit-switcher deflection during opening and closing operations—which can loosen the bus connection—double-acting shock absorbers (catalog number suffix “-H”) are available and are recommended.

⑥ For complete information refer to the “Basis of Fault-Closing Ratings” section on page 2.

⑦ If the circuit-switcher is to be installed on a structure other than S&C Mounting Pedestals (see Table 13 on page 18), detailed drawings of the user-furnished mounting structure must be supplied at the time of order. Please contact your nearest S&C Sales Office for details.

**Table 5. Circuit-Switchers—Three-Pole Center-Break Style, with Aluminum-Sheathed Steel Weldment Bases** ①②③④

Ratings							No. of Interrupting Gaps	Application Classifications (see Table 2 on page 6)	Insulator T.R. No.	Leakage Distance, Inches (mm)	Catalog Number <sup>⑥</sup>	Page Reference for Dimensional Information
kV			Amperes, RMS									
Nom.	Max.	BIL	Cont.	Short-Time		Fault-Closing, Duty-Cycle, Two-Time <sup>⑤</sup>						
				Mom.	3-Sec.							
345	362	1300	1600	70 000	43 750	40 000	3	E●MN	368	231 (5867)	357363	23
			2000	80 000	50 000	40 000	3	E●MN	368	231 (5867)	557363	

- ① Circuit-switchers do not include connectors. Refer to Table 8 on page 15. Circuit-switchers are furnished with gray (Munsell Number 5 BG 7.0/014) station post insulators.
- ② These circuit-switchers cannot be furnished with manual operating handles.
- ③ Shunt-trip device is available with all power-operated center-break style Mark V Circuit-Switchers.
- ④ For center-break style circuit-switchers, blade opening direction, as viewed from interrupter end, is to the left.

- ⑤ For complete information refer to the “Basis of Fault-Closing Ratings” section on page 2.
- ⑥ If the circuit-switcher is to be installed on a structure other than S&C Mounting Pedestals (see Table 13 on page 18), detailed drawings of the user-furnished mounting structure must be supplied at the time of order. Please contact your nearest S&C Sales Office for details.
- Not applicable for fault-interrupting duty. Also suitable for three-phase transformers and three-phase banks of single-phase transformers connected solidly grounded-wye on the primary (circuit-switcher) side, solidly grounded-wye on the secondary side, with a delta-connected tertiary.

**Table 6. Circuit-Switchers—Three-Pole Integer Style** ①②

Ratings							No. of Interrupting Gaps	Application Classifications (see Table 2 on page 6)	Insulator T.R. No.	Leakage Distance, Inches (mm)	Catalog Number <sup>④</sup>		Page Reference for Dimensional Information
kV			Amperes, RMS										
Nom.	Max.	BIL	Cont.	Short-Time		Fault-Closing, Duty-Cycle, Two-Time <sup>③</sup>					Vertical Operating Shaft Inboard	Vertical Operating Shaft Outboard <sup>⑤</sup>	
				Mom.	3-Sec.								
34.5	38	200	1200	61 000	40 000	30 000	1	BEFGHJKLMPR	210	37 (940)	157914	157814	25
46	48.3	250	1200	61 000	40 000	30 000	1	BEFGHJKLMPR	214	43 (1092)	157915	157815	
69	72.5	350	1200	61 000	40 000	30 000	1	BEFGHJKMP	216	72 (1829)	157916	157816	
							2	BEFGHJKLMPR	216	72 (1829)	157926	157826	

- ① Circuit-switchers do not include connectors. Refer to Table 8 on page 15. Circuit-switchers are furnished with gray (Munsell Number 5 BG 7.0/014) station post insulators.
- ② Circuit-switchers do not include manual operating handles. (See Table 9 on page 16).
- ③ For complete information refer to the “Basis of Fault-Closing Ratings” section on page 2.
- ④ If the circuit-switcher is to be installed on a structure other than S&C Mounting Pedestals (see Table 13 on page 18), detailed drawings of the user-furnished mounting structure must be supplied at the time of the order. Please contact your nearest S&C Sales Office for details.
- ⑤ As viewed from interrupter end.

## Ordering Tables

**Table 7. Optional Features—For Mark V Circuit-Switchers**

Item	Suffix to be Added to Circuit-Switcher Catalog Number	Applicable to Circuit-Switcher	
		Style	Rating, kV
Pre-assembled Mark V Circuit-Switcher—provides three pole-units, each consisting of a brain and interrupter assembly, integral disconnect blade, jaw-contact assembly, terminal adapter, support insulators, channel base, and shunt-trip device (when applicable)—all factory-assembled and adjusted	-A	Vertical-break	69 thru 161
		Center-break	230
Shunt-trip device, 48-Vdc control voltage—provides 8-cycle maximum interrupting time for Mark V Circuit-Switcher operated by a Type CS-1A Switch Operator. Not available with manually operated circuit-switchers <sup>①②</sup>	-T1	All	34.5 thru 69
			115 and 138
			161
			230
			345
Shunt-trip device, 125-Vdc control voltage—provides 8-cycle maximum interrupting time for Mark V Circuit-Switcher operated by a Type CS-1A Switch Operator. Not available with manually operated circuit-switchers <sup>①②</sup>	-T2	All	34.5 thru 69
			115 and 138
			161
			230
			345
Bypass accessory, single-pole, stick-operated, set of three, 800 amperes continuous, 20,000 amperes momentary rating—permits exercising of the circuit-switcher and checkout of relaying equipment without opening high-voltage circuit	-B1	Integer and vertical-break	34.5
			46
			69
		Vertical-break	115
Bypass accessory, single-pole, stick-operated, set of three, 1200 amperes continuous, 61,000 amperes momentary rating—permits exercising of the circuit-switcher and checkout of relaying equipment without opening high-voltage circuit	-B2	Vertical-break	138
			34.5
			46
			69
			115
		138	
Center-break <sup>⑤</sup>	161		
Extra-performance closing contacts—provide increased contact life for 34.5-kV through 138-kV vertical-break and integer style circuit-switchers in applications where load in excess of 550 amperes is switched frequently. Each pole-unit set consists of one copper-tungsten arcing-tip assembly in substitution for the standard stainless steel arcing-tip assembly and one carbon arcing-rod assembly with support clamp <sup>③④</sup>	-C1	Integer and vertical-break	230
			34.5 thru 138

① Shunt-trip device control voltage should be the same as switch operator motor and control voltage.

② For shunt-trip insulated operating shafts equipped with resistance-graded (conductive glaze) insulators, refer to your nearest S&C Sales Office.

③ Extra-performance closing contacts (catalog number suffix “-C1”) cannot be used in conjunction with pre-insertion inductors (catalog number suffix “-P5,” “-P51,” “-P6,” or “-P61”), and vice versa.

④ Extra-performance closing contacts can be used on 115-kV and 138-kV circuit-switchers only at installations where the jaw contacts are connected to the source and the interrupters are connected to the load.

⑤ Requires rigid bus connections at rotating-insulator end of the circuit-switcher. To reduce circuit-switcher deflection during opening and closing operations—which can loosen the bus connections—double-acting shock absorbers (catalog number suffix “-H”) are recommended.

TABLE CONTINUED ►

**Table 7. Optional Features—For Mark V Circuit-Switchers—Continued**

Item	Suffix to be Added to Circuit-Switcher Catalog Number	Applicable to Circuit-Switcher	
		Style	Rating, kV
Grounding switch, manual, three-pole, group-operated, 61,000 amperes momentary rating, with flexible straps for current transfer at hinge end of blades, and with 90° opening blades <i>parallel</i> to bases when in open position. Includes manual operating handle <sup>①</sup>	-G2	All	34.5
			46
			69
			115
			138
			161
Grounding switch, manual, three-pole, group-operated, 80,000 amperes momentary rating, with flexible straps for current transfer at hinge end of blades, and with 90° opening blades <i>perpendicular</i> to bases when in open position. Includes manual operating handle <sup>②③</sup>	-G4	Center-break	230
Grounding switch, manual, three-pole, group-operated, 61,000 amperes momentary rating, with flexible straps for current transfer at hinge-end of blades, and with 90° opening blades <i>perpendicular</i> to bases when in open position. Includes manual operating handle	-G22	Vertical-break and center-break	34.5
			46
			69
			115
Grounding switch, manual, three-pole, group-operated, 61,000 amperes momentary rating, with braidless current transfer at hinge-end of blades, and with 90° opening blades <i>perpendicular</i> to bases when in open position. Includes manual operating handle	-G23	Vertical-break and center-break	161
Double-acting shock absorbers—for center-break style circuit-switchers with extruded-aluminum weldment bases. Reduce deflection during opening and closing operations <sup>④</sup>	-H	Center-break	230
Key type interlock, for use on grounding switch (catalog number suffix “-G2” or “-G4”), key to be matched with “Key Interlock with Switch” as optionally furnished with S&C Switch Operators and/or other interlocked device(s). See the “Accessories for Switch Operators” table in S&C Specification Bulletin 719-31, catalog number suffix “-L”; or Table 10 on page 16, catalog number suffix “-L”	-L	All	All
International crating. Wood used is either hardwood or certified by the supplier as “Heat treated (kiln dried) to a core temperature of 133°F (56°C) for a minimum of 30 minutes”	-L71	All	All
Low-temperature interrupters. For applications where temperature regularly falls below -40°F (-40°C). Includes modified red target indicators	-N2	All	All

① Grounding switches opening parallel to bases can only be applied at interrupter end for center-break style circuit-switchers.

② Grounding switches can be applied at rotating-insulator end of center-break style circuit-switchers only by extending bases and adding extra insulator stacks. Refer to your nearest S&C Sales Office.

③ Pre-assembly option “-A” must be specified when ordering grounding switch.

④ Recommended for circuit-switchers furnished with bypass accessory (catalog number suffix “-B2”). Included as standard equipment on circuit-switchers furnished with standard-duty pre-insertion inductors (catalog number suffix “-P5” or “-P51”).

TABLE CONTINUED ►

**Table 7. Optional Features—For Mark V Circuit-Switchers—Continued**

Item		Suffix to be Added to Circuit-Switcher Catalog Number	Applicable to Circuit-Switcher				
Pre-insertion inductors <sup>①②③</sup>	For Capacitor Bank		Style	Rating, kV			
	System Voltage Rating, kV, Nom.	Size, MVAC <sup>④</sup>					
<b>Enhanced-duty pre-insertion inductors<sup>⑤</sup></b> — for circuit-switchers in single-bank capacitor switching applications. Limit inrush current, overvoltage, and audible noise at capacitor bank bus. Also limit switching-surge overvoltages at remote transformers. Not available with manually operated circuit-switchers	34.5	3 to 11	-P6	Integer and vertical-break	34.5		
		12 to 22	-P61				
	46	4 to 18	-P6		69		
		19 to 36	-P61				
	69	5 to 20	-P6	Integer (1 gap)	69		
				Integer (2 gap)			
	69	21 to 42	-P61	Vertical-break	69		
				Integer (1 gap)●			
	Integer (2 gap)●						
	115	10 to 60	-P6	Vertical-break	115		
138	13 to 75	138					
<b>Standard-duty pre-insertion inductors<sup>⑤</sup></b> — for circuit-switchers in single-bank capacitor switching applications. Limit inrush current, overvoltage, and audible noise at capacitor bank bus. Also limit switching-surge overvoltages at remote transformers. Not available with manually operated circuit-switchers	34.5	3 to 33	-P5	Integer and vertical-break	34.5		
	46	4 to 44			46		
	69	5 to 65	-P●	Integer and vertical-break	69		
					-P51●	Integer (1 gap)■▲	69
						Integer (2 gap)■▲	
	115	10 to 84	-P5	Vertical-break	115		
	138	13 to 81			138		
	230	17 to 198			Center-break◆	230	

① Extra-performance closing contacts (catalog number suffix “-C1”) cannot be used in conjunction with pre-insertion inductors (catalog number suffix “-P5”, “-P51”, “-P6”, or “-P61”), and vice versa.

② Circuit-switchers equipped with pre-insertion inductors are not suitable for fault-closing duty.

③ Circuit-switchers equipped with pre-insertion inductors are capable of two consecutive closing operations 5 minutes apart, followed by one closing operation every hour.

④ In some instances, especially for grounded capacitor banks up to 69 kV, larger-size capacitor banks may be accommodated. Refer to your nearest S&C Sales Office.

⑤ For multiple bank (back-to-back) capacitor switching applications or for systems rated above 138 kV, refer to your nearest S&C Sales Office.

● Includes high-strength insulators (T.R. number 278) at jaw-contact end, insulator mounting weldments, and jaw-contact-end mounting brackets.

■ Catalog number suffix “-P5” pre-insertion inductors generally limit, to 2 per unit, overvoltages on unloaded open-ended lines up to 30 miles (48 km) from 5- to 20-MVAC capacitor banks, up to 50 miles (80 km) from 21- to 65-MVAC capacitor banks. For effectiveness up to 50 miles (80 km) from 5- to 20-MVAC capacitor banks, specify catalog number suffix “-P51.”

▲ Includes jaw-contact-end mounting brackets necessary to attain 0.2 ground acceleration seismic loading capability.

◆ Includes double-acting shock absorber on each pole-unit to reduce circuit-switcher deflection during opening and closing operations.

TABLE CONTINUED ►

Table 7. Optional Features—For Mark V Circuit-Switchers—Continued

Item	Suffix to be Added to Circuit-Switcher Catalog Number	Applicable to Circuit-Switcher
		Voltage, Nom., kV
Mark V Circuit-Switcher furnished less insulators <sup>①</sup>	-Z1	34.5
		46
		69
		115
		138
		161
		230
		345
		Voltage, Nom., kV <sup>②</sup> From → To
Mark V Circuit-Switcher furnished with insulators of the next <i>lower</i> voltage rating	-Z2	46 → 34.5
		69 → 46
		115 → 69
		138 → 115
		161 → 138
Mark V Circuit-Switcher furnished with insulators of the next <i>higher</i> voltage rating	-Z3	230 → 161
		34.5 → 46
		46 → 69
		69 → 115
		115 → 138
		138 → 161
		161 → 230

① Not available for integer-style switches.

② In instances where insulators of the next-lower or next-higher voltage rating have different bolt-circle dimensions, adapters are required; refer to your nearest S&C Sales Office.

Table 8. Connectors<sup>①</sup>

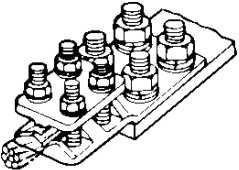
Illustration	Description	Accommodating Conductor	Catalog Number <sup>②</sup>
	Standard bronze pad terminal, four-bolt, tin plated. Includes ½-inch galvanized steel hardware for attachment to terminal pads of the circuit-switchers	2/0 stranded (67.4 mm <sup>2</sup> ) through 800 kc mil (405 mm <sup>2</sup> ) copper	4568R1
		4/0 stranded (107 mm <sup>2</sup> ) through 1000 kc mil (507 mm <sup>2</sup> ) copper	4569R1
	Standard aluminum-alloy pad terminal, four-bolt. Includes ½-inch galvanized steel hardware for attachment to terminal pads of circuit-switchers	250 kc mil (127 mm <sup>2</sup> ) through 400 kc mil (203 mm <sup>2</sup> ) copper or aluminum	5329
		350 kc mil (177 mm <sup>2</sup> ) through 600 kc mil (304 mm <sup>2</sup> ) copper or aluminum	5331
		600 kc mil (304 mm <sup>2</sup> ) through 900 kc mil (456 mm <sup>2</sup> ) copper or aluminum	5333
		900 kc mil (456 mm <sup>2</sup> ) through 1250 kc mil (633 mm <sup>2</sup> ) copper or aluminum	5334

① Connectors listed are suitable only for applications through 161 kV. For connectors for higher voltage applications, contact the nearest S&C Sales Office.

② Add suffix letter to the catalog number to specify appropriate mounting bolt length as follows:

- “-A” for ½–13×1
- “-B” for ½–13×1½
- “-C” for ½–13×2

## Ordering Tables

**Table 9. S&C Manual Geared Operating Handle—For Mark V Circuit-Switchers**

Item	Catalog Number
Manual geared operating handle	5291●

● Includes appropriate flexible coupling for connection of output shaft of operating handle to vertical operating pipe of the circuit-switcher. For other applications of manual geared operating handle, specify flexible coupling matched to size of vertical operating pipe. See Table 10.

Manual operating handles are available with all integer-style and vertical-break style circuit-switchers, and with all center-break style circuit-switchers with extruded-aluminum weldment bases. Manually

operated circuit-switchers have no fault-closing ratings, and cannot be provided with shunt-trip device.

The degree of simultaneity of opening and closing of the three pole-units of a manually operated circuit-switcher is dependent on the proper installation and adjustment of the operating mechanism—as well as on the speed of cranking at the operating handle—and must be considered in establishing ground-relay settings.

**Table 10. Accessories—For Manual Geared Operating Handle**

Item	Suffix to be Added to Operating Handle Catalog Number
Flexible coupling—for use with 1½-inch IPS vertical operating pipe (comes standard when manual geared operating handle is ordered with a circuit-switcher)	-F1
Flexible coupling—for use with 2-inch IPS vertical operating pipe (comes standard when manual geared operating handle is ordered with a circuit-switcher)	-F2
Flexible coupling—for use with 2½-inch IPS vertical operating pipe (comes standard when manual geared operating handle is ordered with a circuit-switcher)	-F3
Flexible coupling—for use with 3-inch IPS vertical operating pipe (comes standard when manual geared operating handle is ordered with a circuit-switcher)	-F4
Key interlock, locks circuit-switcher open	-L
Auxiliary switch (individually adjustable contacts), 4-PST—coupled to circuit-switcher①	-Q
Auxiliary switch (individually adjustable contacts), 8-PST—coupled to circuit-switcher①	-W

① The 4-PST Auxiliary Switch (catalog number suffix “-Q”) cannot be furnished if the 8-PST version (catalog number suffix “-W”) is specified, and vice versa.

**Table 11. Spare or Replacement Interrupters—For Mark V Circuit-Switchers**

Item	For Mark V Circuit-Switcher		Obsolete Catalog Number	Replacement Catalog Number <sup>①②</sup>	Replacement Catalog Number (Low-Temperature) <sup>③</sup>
	Style	No. of Interrupting Gaps			
Interrupter, single-gap	Integer	1	SA-40315	SA-43826-A●	SA-43826-1-A
		1	SA-40316	SA-43827-A■	SA-43827-1-A
	Vertical-break and center-break	1	SA-40316	SA-43827-A	SA-43827-1-A
Interrupter, 2-gap	Integer vertical-break and center-break	2	SA-40317	SA-43828-A	SA-43828-1-A
Interrupter, 3-gap	Vertical-break and center-break	3	SA-40318	SA-43829-A	SA-43829-1-A

① When ordering, please state mounting position of circuit-switcher, viz., upright or vertical.

② Elastomeric-seal interrupters exhibiting low gas-pressure indication (red target) and having porcelain housing in good condition can be exchanged for new interrupters. Elastomeric-seal interrupters can be identified by the dome-shaped pressure-relief vent cover. To ensure proper handling, refer to the nearest S&C Sales Office and obtain a special serially numbered label to place on the shipping container. Enclose a packing slip showing purchase order or requisition number covering the exchange and ship the replaced interrupter, transportation

charges prepaid, to S&C Electric Company, Repair Center, 1800 Devon Avenue, Chicago, Illinois 60660-1010.

③ Low-temperature interrupter intended for circuit-switchers with the “-N2” option.

- For use on circuit-switcher catalog numbers: 157814, 157815, 157816 157914, 157915, 157916
- For use on circuit-switcher catalog numbers: 157886, 157986

**Table 12. Parts**

Item	Catalog Number
SF <sub>6</sub> reclamation tool—assists reclaiming SF <sub>6</sub> from discontinued solder-seal interrupters. (Solder-seal interrupters have flat pressure-relief vent cover.) User-furnished SF <sub>6</sub> reclamation equipment required	SXA-2213

**Table 13. Mounting Pedestals and Anchor Bolts—For Mark V Circuit-Switchers**

Item	For Circuit-Switcher		Phase Spacing, Inches (mm)	Column Section, Inches (mm)	Column Height <sup>①</sup> , Feet (mm)	Catalog Number	Anchor Bolts <sup>②③</sup>			
	Style	Rating, kV					Qty. Req'd.	Catalog Number		
Mounting pedestals (one per set), single rectangular tubular column, formed steel plate construction, galvanized finish	Integer <sup>④</sup>	34.5 thru 69 1 and 2 gaps	●	10×18 (254×457)	8 (2438)	92450R1-G	4	S-81365-2		
					9 (2743)	92451R1-G				
					10 (3048)	92452R1-G				
					11 (3353)	92453R1-G				
					12 (3658)	92454R1-G				
Mounting pedestals, set of two, square steel tube construction, complete with Circuit-Switcher support frame, galvanized finish	Vertical-break and center-break	69 thru 115 1 and 2 gaps	96 (2438)	12×12 (305×305)	8 (2438)	90100R1-G	8	S-81365-1		
					9 (2743)	90101R1-G				
					10 (3048)	90102R1-G				
					11 (3353)	90103R1-G				
					12 (3658)	90104R1-G				
	Vertical-break	138 1, 2, and 3 gaps	96 (2438)	12×12 (305×305)	8 (2438)	90100R1-G				
					9 (2743)	90101R1-G				
					10 (3048)	90102R1-G				
					11 (3353)	90103R1-G				
					12 (3658)	90104R1-G				
	Center-break <sup>⑤</sup>	138 1, 2, and 3 gaps	108 (2743)	12×12 (305×305)	8 (2438)	90120R1-G				
					9 (2743)	90121R1-G				
					10 (3048)	90122R1-G				
					11 (3353)	90123R1-G				
					12 (3658)	90124R1-G				
	Vertical-break	161 2 and 3 gaps	108 (2743)	12×12 (305×305)	8 (2438)	90120R1-G			8	S-81365-2
					9 (2743)	90121R1-G				
				14×14 (356×356)	10 (3048)	90132R1-G				
					11 (3353)	90133R1-G				
	Vertical-break and center-break	161 2 and 3 gaps	123 (3124)	12×12 (305×305)	8 (2438)	90140R1-G			8	S-81365-1
9 (2743)					90141R1-G					
14×14 (356×356)				10 (3048)	90152R1-G					
				11 (3353)	90153R1-G					
Center-break	230 3 gaps extruded-aluminum weldment bases	Not applicable	12×12 (305×305)	8 (2438)	90180R1-G	24	S-81365-2			
				9 (2743)	90181R1-G					
				10 (3048)	90182R1-G					
				11 (3353)	90183R1-G					
Center-break	345 3 gaps aluminum-sheathed steel weldment bases	Not applicable	16×16 (406×406)	10 (3048)	90162R3-G	24	S-81365-3			
				11 (3353)	90163R3-G					
				12 (3658)	90164R3-G					

① Mounting pedestals of less than 12-foot (366-cm) column height may be furnished in intermediate heights—in 3-inch (76-mm) increments, as shown in the table below. Add the appropriate suffix to the mounting pedestal set catalog number.

Additional Column Heights, Inches (mm)	Mounting Pedestal Catalog Number Suffix
3 (76)	-S3
6 (152)	-S6
9 (229)	-S9

**NOTE:** Maximum standard column height is 12 feet (366 cm).

② Each anchor bolt is of galvanized steel and is furnished with two hex nuts and two flat washers to facilitate leveling the mounting pedestals.

③ Nominal sizes of anchor bolts are as follows, in inches:

- S-81365-1: 1×33
- S-81365-2: 1¼×44
- S-81365-3: 1½×55

④ If mounting pedestals are to be used with integer-style circuit-switchers that are equipped with the shunt-trip device, add suffix “-T” to the catalog number.

⑤ Vertical-break style circuit-switchers, one, two, or three gaps, rated 138 kV, will also fit these mounting pedestals.

● Phase spacing for integer-style circuit-switchers is fixed by the dimensions of the mounting frame and is 41 inches (104 cm) for circuit-switchers rated 34.5 kV and 46 kV, and 51 inches (130 cm) for circuit-switchers rated 69 kV.

**Three-Pole Vertical-Break Style**  
 34.5 kV through 161 kV

Dimensions in inches (mm)

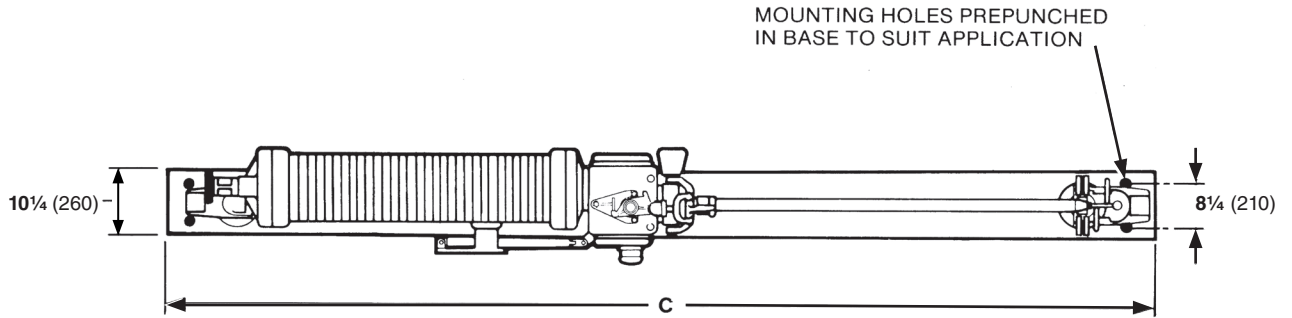

POLE-UNIT TOP VIEW

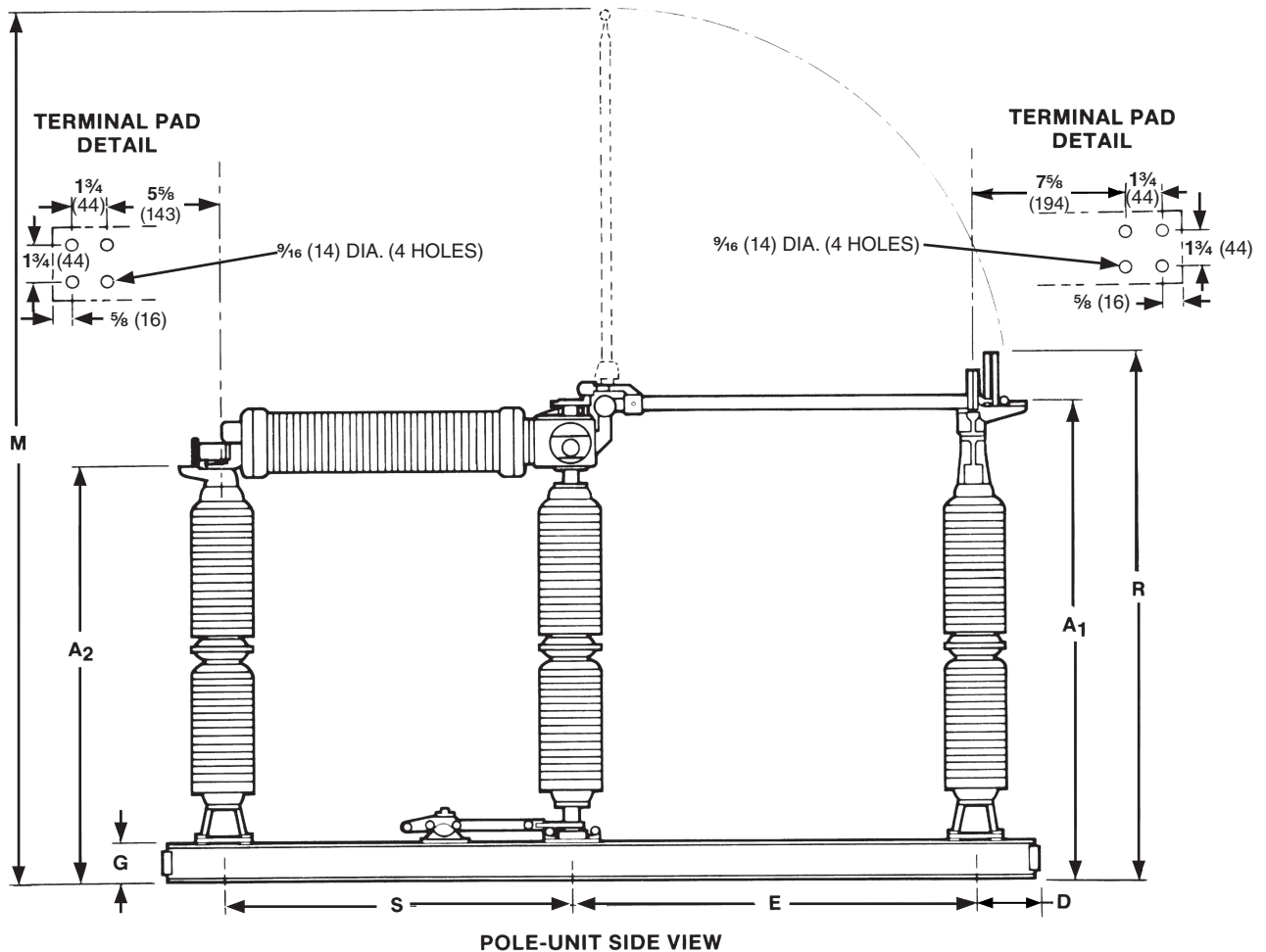

POLE-UNIT SIDE VIEW

## Dimensional Drawings

Catalog Number ②③④	Dimensions in Inches (mm)									Net Wt. per Pole-Unit, Lbs. (kg)
	A1	A2	C	D	E	G	M	R	S	
157314	46½ (1181)	34¾ (873)	96 (2438)	11½ (283)	29 (737)	6 (152)	74¼ (1886)	56¼ (1429)	44¾ (1137)	680 (308)
157315	50½ (1283)	38¾ (975)	104 (2642)	13½ (333)	33 (838)	6 (152)	82¼ (2089)	60¼ (1530)	44¾ (1137)	740 (336)
157316	58½ (1486)	46¾ (1178)	110 (2794)	11½ (283)	43 (1092)	6 (152)	100¼ (2546)	68¼ (1734)	44¾ (1137)	850 (386)
157326	58½ (1486)	46¾ (1178)	118 (2997)	11½ (283)	43 (1092)	6 (152)	100¼ (2546)	68¼ (1734)	52⅞ (1343)	890 (404)
157318	75⅝ (1921)	63½ (1613)	128 (3251)	11½ (283)	61 (1549)	7 (178)	136¾ (3464)	85¾ (2169)	44¾ (1137)	1145 (519)
157328	75⅝ (1921)	63½ (1613)	138 (3505)	12½ (308)	61 (1549)	7 (178)	136¾ (3464)	85¾ (2169)	52⅞ (1343)	1185 (538)
157329	84¾ (2149)	72½ (1842)	146 (3708)	11½ (283)	71 (1803)	7 (178)	155¾ (3947)	94¾ (2397)	52⅞ (1343)	1275 (578)
157369	84¾ (2149)	72½ (1842)	165 (4191)	11½ (283)	71 (1803)	7 (178)	155¾ (3947)	94¾ (2397)	71½ (1816)	1390 (630)
157320	92⅝ (2353)	80½ (2045)	154 (3912)	11½ (283)	79 (2007)	7 (178)	171¾ (4353)	102¾ (2600)	52⅞ (1343)	1375 (624)
157360	92⅝ (2353)	80½ (2045)	173 (4394)	11½ (283)	79 (2007)	7 (178)	171¾ (4353)	102¾ (2600)	71½ (1816)	1490 (676)

② Connectors not included. For available connectors refer to Table 8 on page 15. Circuit-Switchers are furnished with gray (Munsell Number 5 BG 7.0/014) station post insulators.

③ Manual operating handle not included. (See Table 9 on page 16.)

④ Shunt-trip device is available with all power-operated vertical-break style Mark V Circuit-Switchers.

**Three-Pole Center-Break Style**  
with extruded-aluminum weldment bases 230 kV

Dimensions in inches (mm)

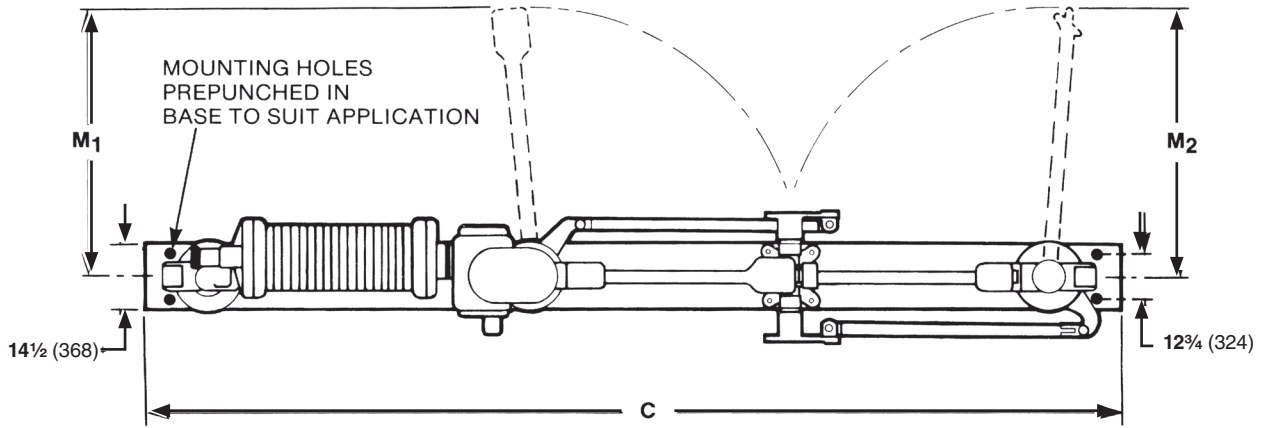

POLE-UNIT TOP VIEW



TERMINAL PAD DETAIL

TERMINAL PAD DETAIL

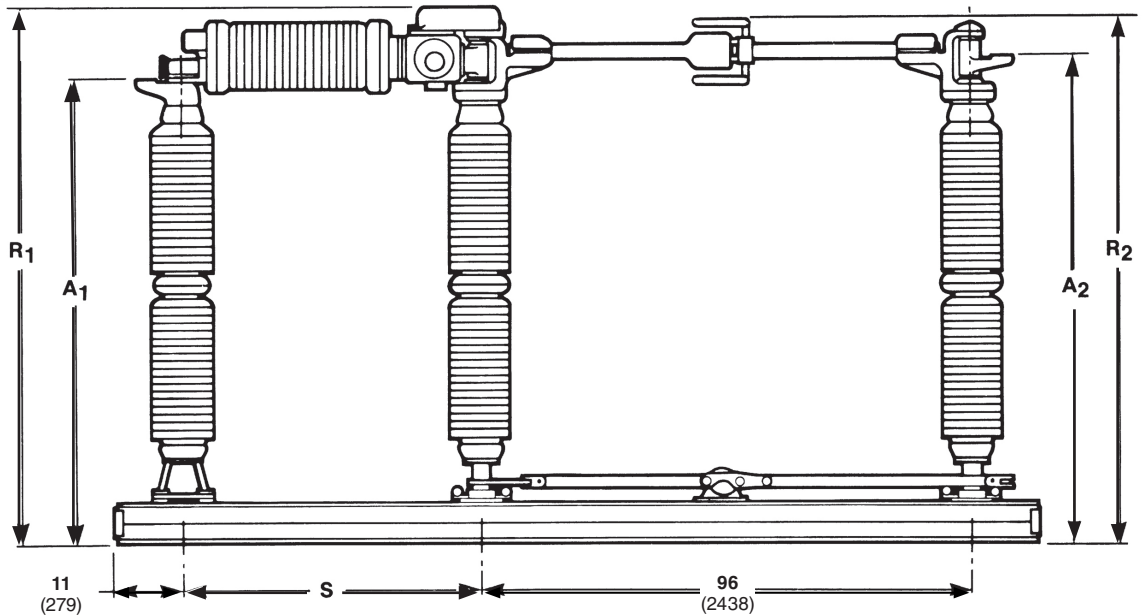

POLE-UNIT SIDE VIEW

## Dimensional Drawings

Catalog Number ②③④⑤⑥	Dimensions in Inches (mm)									Net Wt. per Pole-Unit, Lbs. (kg)
	A1	A2	C	G	M1	M2	R1	R2	S	
657361R2	99 (2515)	103 (2616)	197 (5004)	5 (127)	51¼ (1314)	54½ (1384)	112¼ (2864)	112½ (2858)	79½ (2019)	1850 (839)
757361R2	100¼ (2546)	104½ (2654)	201 (5105)	7½ (191)	51¼ (1302)	56¼ (1429)	114 (2896)	114¼ (2902)	83½ (2121)	1958 (888)

② Connectors not included. For available connectors refer to Table 8 on page 15. Circuit-switchers are furnished with gray (Munsell Number 5 BG7.0/014) station post insulators.

③ Manual operating handle not included. (See Table 9 on page 16.)

④ Shunt-trip device is available with all power-operated center-break style Mark V Circuit-Switchers.

⑤ For center-break style circuit-switchers, blade opening direction, as viewed from interrupter end, is to the left.

⑥ Flexible-conductor connections are recommended at both ends of all center-break style circuit-switchers with extruded-aluminum weldment bases, except when the bypass accessory (catalog number suffix "-B2") is furnished. In this instance, rigid bus connections are necessary at the rotating-insulator end. To reduce circuit-switcher deflection during opening and closing operations—which can loosen the bus connections—double-acting shock absorbers (catalog number suffix "-H") are available and are recommended.

**Three-Pole Center-Break Style**  
with aluminum-sheathed weldment bases 345 kV

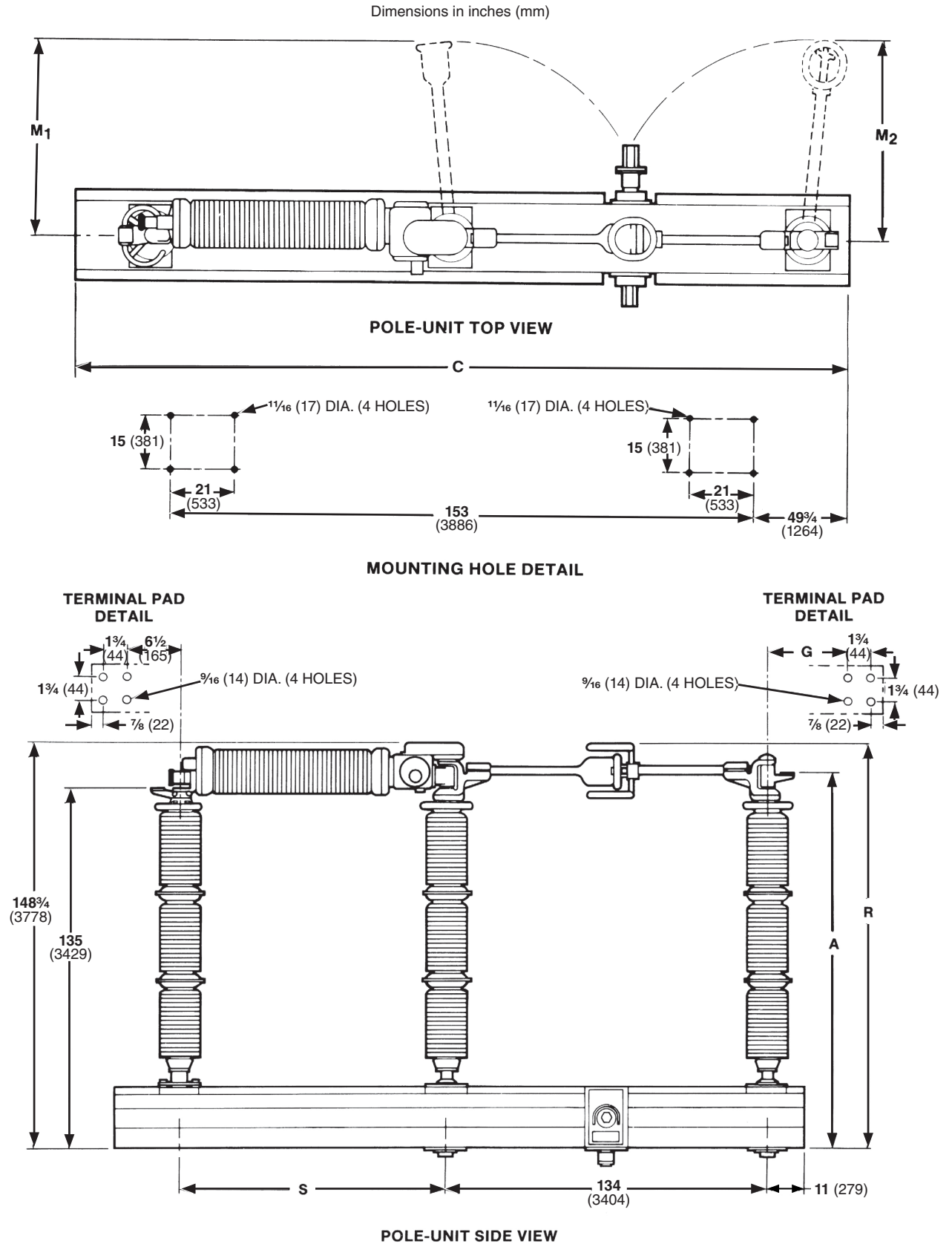

## Dimensional Drawings

Catalog Number <sup>②③④⑤</sup>	Dimensions in Inches (mm)							Net Wt. per Pole-Unit, Lbs. (kg)
	A	C	G	M1	M2	R	S	
357363	139 (3531)	231 (5867)	5 (127)	70¾ (1797)	74½ (1892)	150½ (3823)	79½ (2019)	4775 (2166)
557363	140¼ (3562)	235 (5969)	7½ (191)	71¼ (1810)	78⅞ (2003)	152 (3861)	83½ (2121)	4900 (2223)

② Connectors not included. For available connectors refer to Table 8 on page 15. Circuit-switchers are furnished with gray (Munsell Number 5 BG7.0/014) station post insulators.

③ These circuit-switchers cannot be furnished with manual operating handle.

④ Shunt-trip device is available with all power-operated center-break style Mark V Circuit-Switchers.

⑤ For center-break style circuit-switchers, blade opening direction, as viewed from interrupter end, is to the left.

**Three-Pole Integer Style**  
34.5 kV through 69 kV

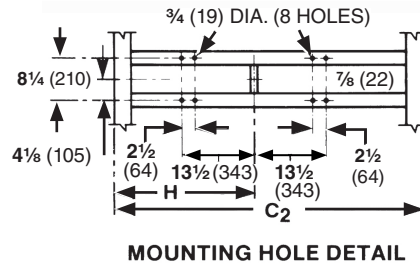
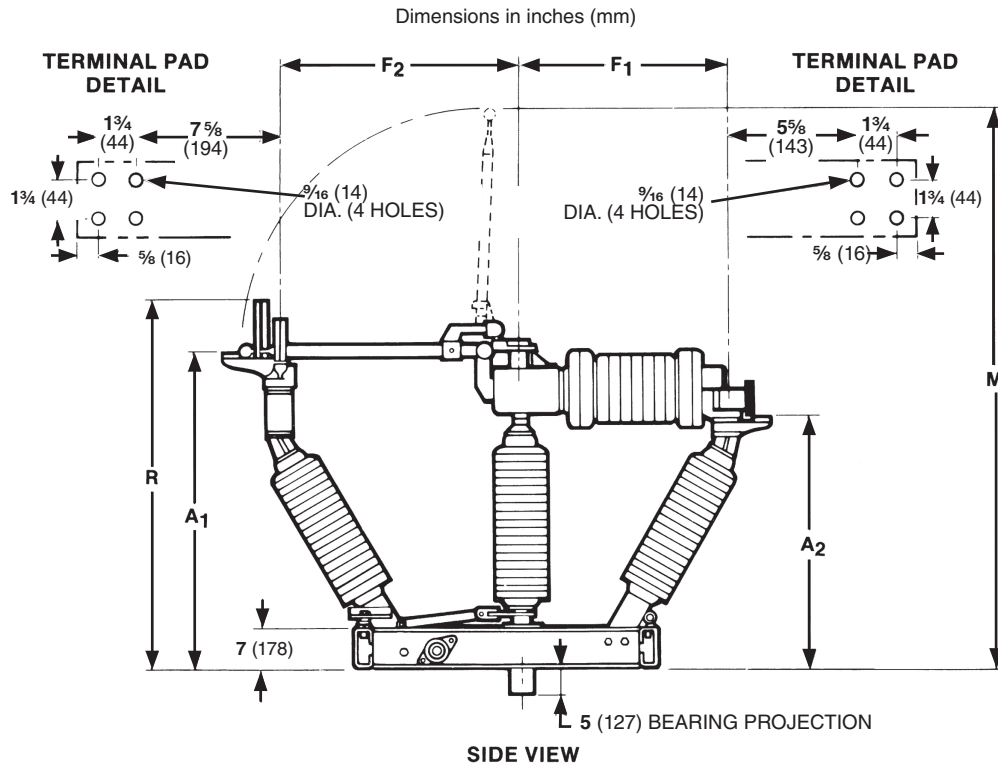

# Dimensional Drawings

Dimensions in inches (mm)

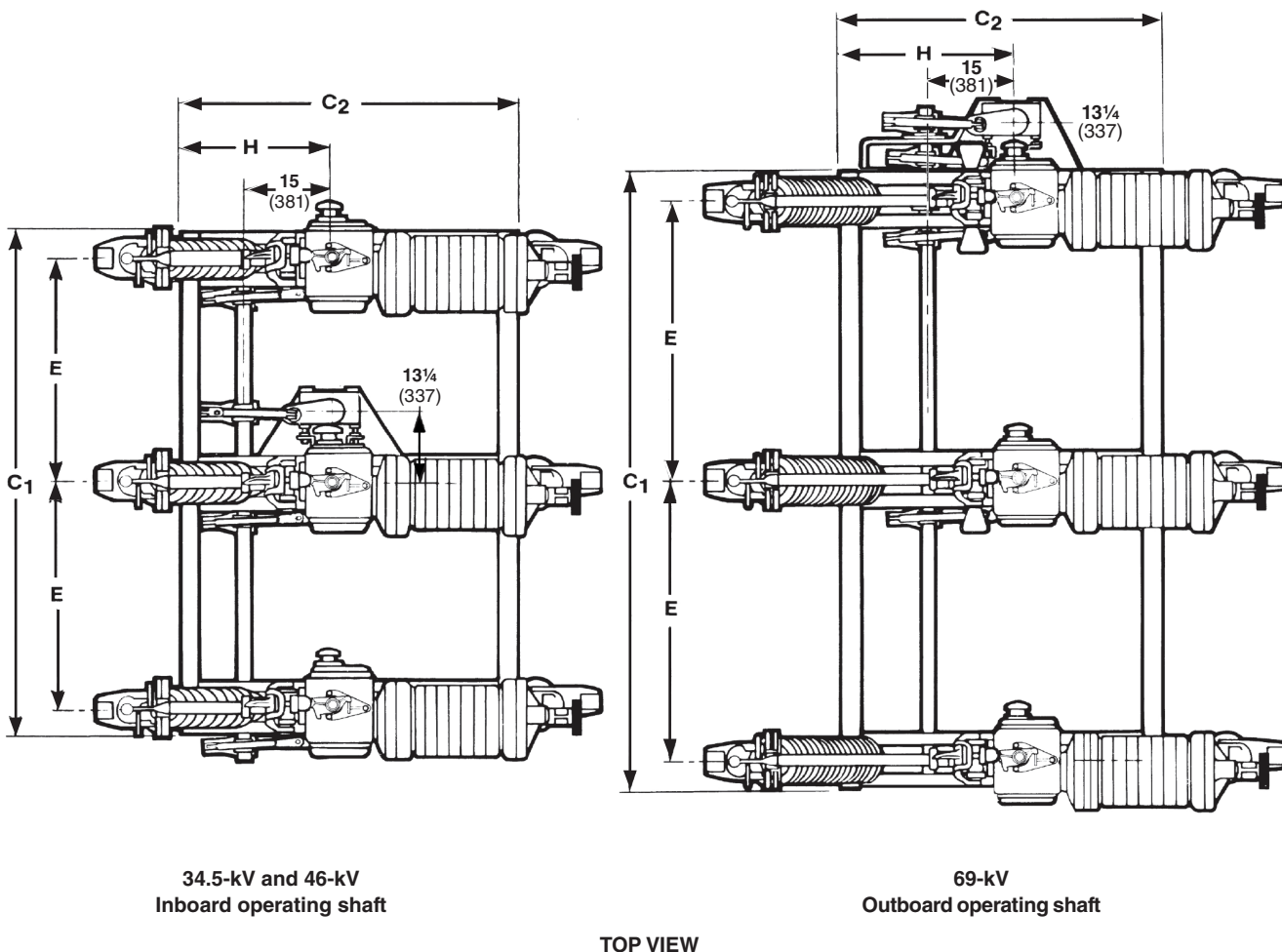

Catalog Number <sup>②③④⑤</sup>		Dimensions in Inches (mm)										Net Wt. per Integer-Unit, Lbs. (kg)
Vertical Operating Shaft Inboard	Vertical Operating Shaft Outboard on Right <sup>⑤</sup>	A1	A2	C1	C2	E	F1	F2	H	R	M	
157914	157814	44 <sup>3</sup> / <sub>4</sub> (1137)	32 <sup>5</sup> / <sub>8</sub> (829)	92 (2337)	57 <sup>1</sup> / <sub>2</sub> (1461)	41 (1041)	37 <sup>1</sup> / <sub>4</sub> (946)	29 (737)	26 (660)	54 <sup>1</sup> / <sub>2</sub> (1384)	72 <sup>1</sup> / <sub>2</sub> (1842)	2250 (1021)
157915	157815	48 <sup>3</sup> / <sub>4</sub> (1238)	36 <sup>5</sup> / <sub>8</sub> (930)	92 (2337)	57 <sup>1</sup> / <sub>2</sub> (1461)	41 (1041)	37 <sup>1</sup> / <sub>4</sub> (946)	33 (838)	26 (660)	58 <sup>1</sup> / <sub>2</sub> (1486)	80 <sup>1</sup> / <sub>2</sub> (2045)	3040 (1379)
157916	157816	56 <sup>3</sup> / <sub>4</sub> (1441)	44 <sup>5</sup> / <sub>8</sub> (1133)	112 (2845)	55 (1397)	51 (1295)	37 <sup>1</sup> / <sub>4</sub> (946)	43 (1092)	30 <sup>1</sup> / <sub>2</sub> (775)	66 <sup>1</sup> / <sub>2</sub> (1689)	98 <sup>1</sup> / <sub>2</sub> (2502)	3250 (1474)
157926	157826	56 <sup>3</sup> / <sub>4</sub> (1441)	44 <sup>5</sup> / <sub>8</sub> (1133)	112 (2845)	62 (1575)	51 (1295)	52 <sup>1</sup> / <sub>8</sub> (1343)	43 (1092)	30 <sup>1</sup> / <sub>2</sub> (775)	66 <sup>1</sup> / <sub>2</sub> (1689)	98 <sup>1</sup> / <sub>2</sub> (2502)	3600 (1633)

② Connectors not included. For available connectors refer to Table 8 on page 15. Circuit-Switchers are furnished with gray (Munsell Number 5 BG7.0/014) station post insulators.

③ Manual operating handle not included. (See Table 9 on page 16.)

④ Shunt-trip device is available with all power-operated vertical-break style Mark V Circuit-Switchers.

⑤ As viewed from interrupter end.